

MX built-in pressure gauge

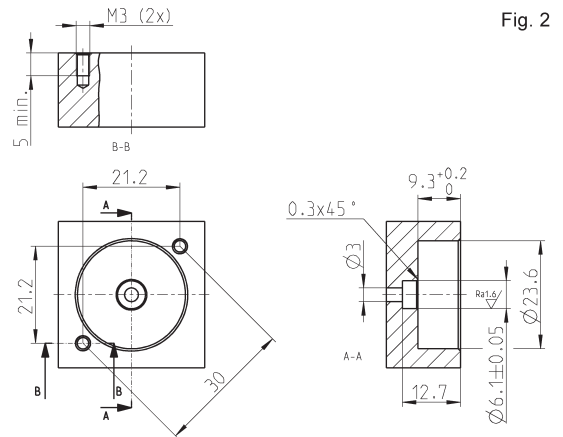

The kit is supplied with:
 1 pressure gauge
 1 seal
 2 screws

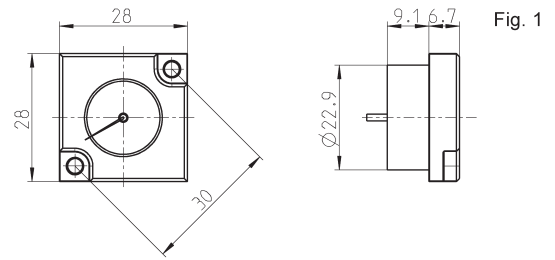

Mod.	Range
MX3-R30/W-P	0 ÷ 2.5 bar
MX3-R31/W-P	0 ÷ 6 bar
MX3-R32/W-P	0 ÷ 10 bar
MX3-R33/W-P	0 ÷ 12 bar

Fig. 1 = pressure gauge
 Fig. 2 = seat

O-ring for assembling

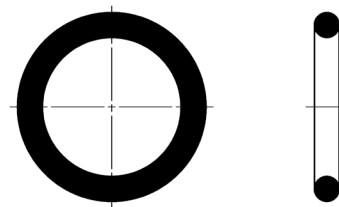

Mod.	O-ring	For assembly
160-39-11/19	OR 3125	MX2
OR 38X2,8 NBR	OR 38X2,8	MX3