

Series MX filters

New versions

MX2 ports: G3/8, G1/2, G3/4 - MX3 ports: G3/4, G1
Modular
Bowl with technopolymer cover and bayonet-type mounting



- » Removal of impurities and condensate
- » High flow with minimum pressure decreases
- » Quality of delivered air according to ISO 8573-1:2010, Classes 7.8.4 and 6.8.4
- » Manual, automatic or depressuring drain
- » Polymer bowl locking system reducing the risk of accidents
- » Visual blockage indicator
- » Metal bowl also available

The Series MX air treatment components are characterized by a modern, linear and compact design, offering high performances. The perfect integration between metal alloys and technopolymers has allowed the realization of a reliable product, light and strong at the same time. Thanks to a new concept of modularity, moreover, the mounting of components has become easier.

The Series MX has been realized to offer a multi-sector solution that guarantees saving in terms of installation time, space and costs.

A special configurator, available on Camozzi website at <http://catalogue.camozzi.com> (Configurators section), allows the customer to choose the most suitable solution for his application, selecting single components or by configuring assembled FRLs.

GENERAL DATA

Construction	modular, compact with filtering element in HDPE
Materials	see TABLE OF MATERIALS on the following page
Ports	MX2: G3/8 - G1/2 - G3/4 MX3: G3/4 - G1
Condensate capacity	MX2: 55 cm ³ MX3: 85 cm ³
Mounting	vertical in-line wall-mounting (by means of clamps)
Operating temperature	-5°C ÷ 50°C up to 16 bar (with the dew point of the fluid lower than 2°C at the min. working temperature) -5°C ÷ 60°C up to 10 bar (with the dew point of the fluid lower than 2°C at the min. working temperature)
Quality of delivered air according to ISO 8573-1:2010	Class 6.8.4 with 5 µm filtering element Class 7.8.4 with 25 µm filtering element
Operating pressure	0.3 ÷ 16 bar (with automatic drain 1.5 ÷ 12 bar)
Nominal flow	see FLOW DIAGRAMS on the following pages
Fluid	compressed air

CODING EXAMPLE

MX	2	-	1/2	-	F	0	0	M	1	-	LH
-----------	----------	----------	------------	----------	----------	----------	----------	----------	----------	----------	-----------

MX	SERIES
2	SIZE: 2 = G3/8 - G1/2 - G3/4 3 = G3/4 - G1
1/2	PORT: 3/8 = G3/8 1/2 = G1/2 3/4 = G3/4 1 = G1
F	FILTER
0	FILTERING ELEMENT: 0 = 25 µm (standard) 1 = 5 µm
0	DRAINING OF CONDENSATE (further details in the dedicated section): 0 = semiautomatic-manual drain (standard - only for polymer bowl) 3 = automatic drain 5 = depressuring drain, protected (only for polymer bowl) 8 = without drain, with port G1/8
M	TYPE OF BOWL: = polymer (standard) M = metal (only for MX2-1/2 and MX3-1)
1	VISUAL BLOCKAGE INDICATOR: = not present 1 = present
LH	FLOW DIRECTION: = from left to right (standard) LH = from right to left

For the assembly of a single component with fixing flanges or wall-mounting, see the section "FRL Series MX Assembled"

Filters Series MX - materials

A = Filter

B = Filter with visual blockage indicator

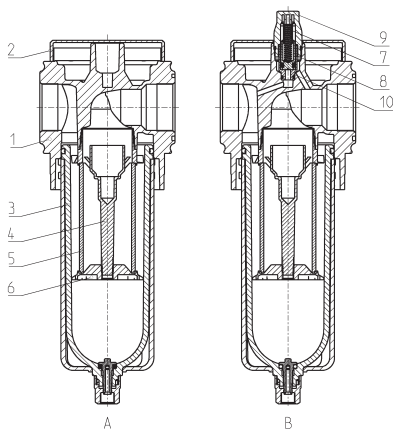

PARTS	MATERIALS
1 = Body	Aluminium
2 = Covering	Polyacetal
3 = Bowl / bowl cover	Polycarbonate/Polyamide/Aluminium
4 = Valve-guide	Polyacetal
5 = Filtering element	Polyethylene
6 = Separation deflector	Polyacetal
7 = Upper spring	Stainless steel
8 = Piston	Anodized aluminium
9 = Visual blockage indicator	Polycarbonate
10 = Indicator body	Brass
Seals	NBR

MX2 FILTERS FLOW DIAGRAMS

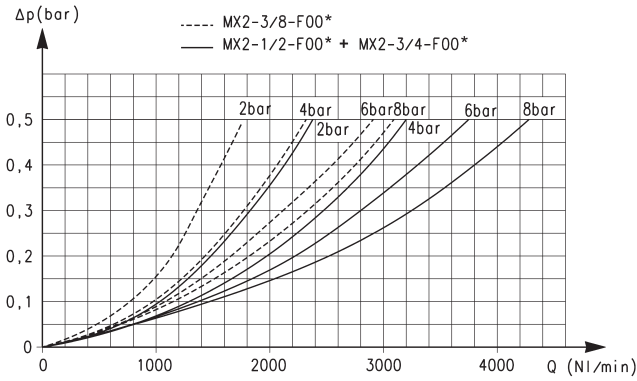

* Reference diagram for models with filtering element = 25 µm

Δp = Pressure drop (bar)
Q = Flow (NL/min)

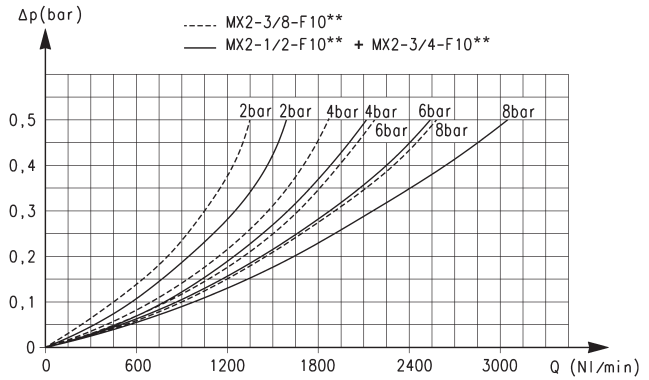

** Reference diagram for models with filtering element = 5 µm

Δp = Pressure drop (bar)
Q = Flow (NL/min)

MX3 FILTERS FLOW DIAGRAMS

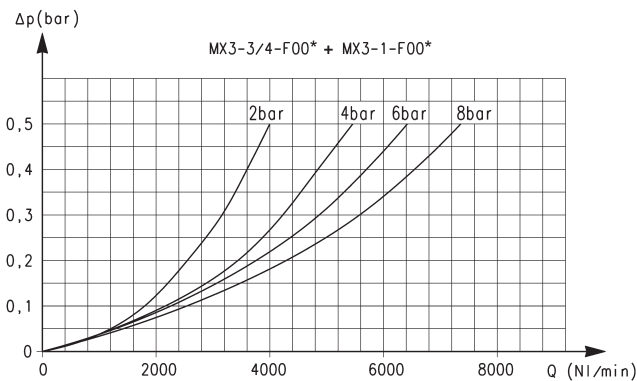

* Reference diagram for models with filtering element = 25 µm

Δp = Pressure drop (bar)
Q = Flow (NL/min)

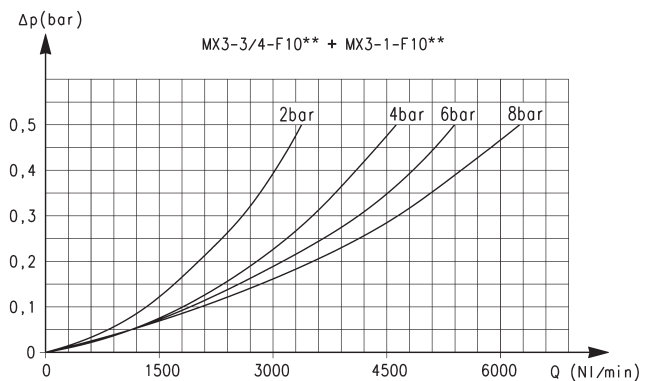

** Reference diagram for models with filtering element = 5 µm

Δp = Pressure drop (bar)
Q = Flow (NL/min)

Filters Series MX - dimensions

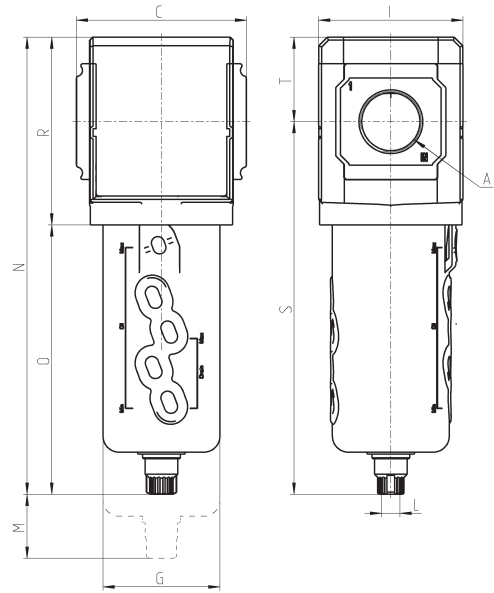

Mod.	A	C	G	I	L	M	N	O	R	S	T	Weight (Kg)
MX2-3/8-F00	G3/8	70	55.3	68	G1/8	57.5	212	127	85	174.5	37.5	0.5
MX2-1/2-F00	G1/2	70	55.3	68	G1/8	57.5	212	127	85	174.5	37.5	0.5
MX2-3/4-F00	G3/4	70	55.3	68	G1/8	57.5	212	127	85	174.5	37.5	0.5
MX3-3/4-F00	G3/4	89.5	61.5	76	G1/8	75	241	142	99	196.5	44.5	0.8
MX3-1-F00	G1	89.5	61.5	76	G1/8	75	241	142	99	196.5	44.5	0.8
MX2-1/2-F03M	G1/2	70	60	68	G1/8	57.5	205	120	85	167.5	37.5	0.6
MX3-1-F03M	G1	89.5	67	76	G1/8	75	233	134	99	188.5	44.5	0.8

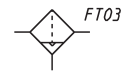
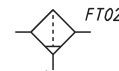
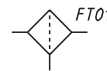

FT01 = filter with direct G1/8 exhaust

FT02 = filter with semi-automatic manual drain

FT03 = filter with automatic/ depressuring drain

Filters Series MX - dimensions

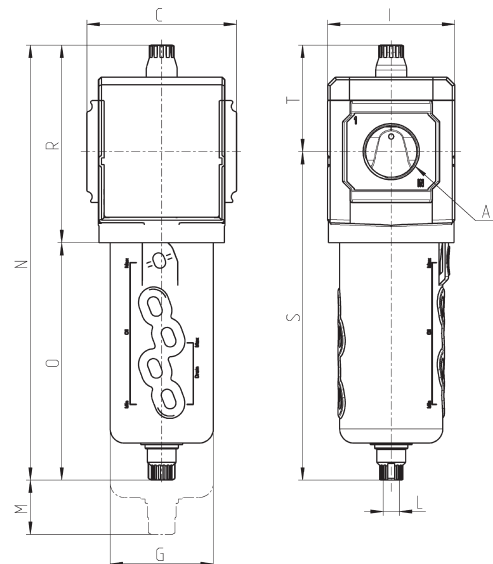

Mod.	A	C	G	I	L	M	N	O	R	S	T	Weight (Kg)
MX2-3/8-F001	G3/8	70	55.3	68	G1/8	57.5	231	127	104	174.5	56.5	0.5
MX2-1/2-F001	G1/2	70	55.3	68	G1/8	57.5	231	127	104	174.5	56.5	0.5
MX2-3/4-F001	G3/4	70	55.3	68	G1/8	57.5	231	127	104	174.5	56.5	0.5
MX3-3/4-F001	G3/4	89.5	61.5	76	G1/8	75	260	142	118	196.5	63.5	0.8
MX3-1-F001	G1	89.5	61.5	76	G1/8	75	260	142	118	196.5	63.5	0.8
MX2-1/2-F03M1	G1/2	70	60	68	G1/8	57.5	224	120	104	167.5	56.5	0.6
MX3-1-F03M1	G1	89.5	67	76	G1/8	75	252	134	118	188.5	63.5	0.8



FT05 = filter with direct G1/8 exhaust and visual blockage indicator

FT06 = filter with semi-automatic manual drain and visual blockage indicator

FT07 = filter with automatic/ depressuring drain and visual blockage indicator