

Test point valve Mod. VPC2

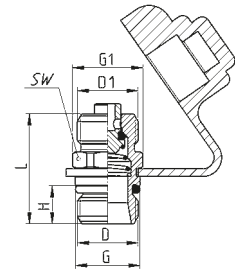

CHARACTERISTICS

Mod.	D	D1	H	G	G1	L	SW	Weight (g)	Pack. (pcs)
VPC2 M16X1,5-M16X1,5R	M16X1,5	M16X1,5	10	17	18,5	29	17	33	10
VPC2 M22X1,5-M16X1,5R	M22X1,5	M16X1,5	10	23	18,5	29	17	41	10

Drain valve Mod. VDC2

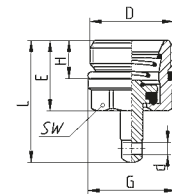

CHARACTERISTICS

Mod.	D	d	E	G	H	L	SW	Weight (g)	Pack. (pcs)
VDC2 M22X1,5R	M22X1,5	3,2	18,5	23	10	32,1	19	29	10

Tyre inflator valve Mod. V604



A = rod position for tyre inflation
B = rod position for tank filling through air intake for tyre inflation

2 = energy supply
3 = drain
11, 12 = energy flow

Flow 2 ÷ 11 bar at 6 bar ΔP 1: 1620 l/min
Flow 2 ÷ 12 bar at 6 bar with no interruption: 400 l/min
Safety pressure: 10 bar Q = 100 l/min; 8 bar Q = 0 l/min

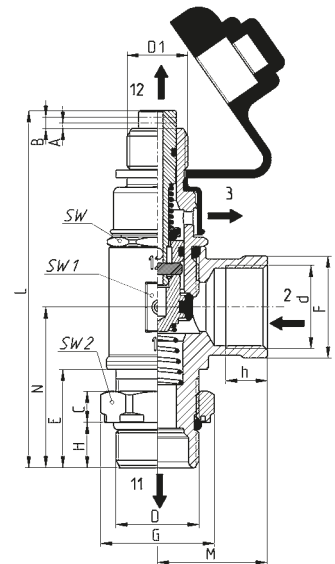

CHARACTERISTICS

Mod.	C	D	D1	d	E	F	G	H	h	L	M	N	SW	SW1	SW2	Weight (g)	Pack. (pcs)
V604 M22X1,5R	8,2	M22X1,5	M16X1,5	M22X1,5	26	27	30	12	11	94,4	29	42,5	24	27	27	253	2