

# Series CGPT self-centering parallel grippers with T-guide

Single and double acting, magnetic, self-centering  
Bores:  $\varnothing$  16, 20, 25, 32, 40 mm



Thanks to the use of a high performing and precise force transmission system, the Series CGPT grippers are able to provide high gripping forces while guaranteeing a very high repeatability.

The wide range of sizes available allows you to find the best solution for any need of movement. The grippers are supplied with centering bushes (tolerance H8) which, once positioned on the body and/or on the jaws, are able to guarantee, during maintenance, a high interchangeability of the gripper and of the extensions.

- » Robust, compact and light design
- » High closing/opening forces
- » Fixing from the top, from below and from the side
- » Supply on the side or on the bottom (even without using tubes)
- » Self-centering jaws
- » High closing and opening repeatability
- » High interchangeability (centering bushes)
- » Position detection thanks to the use of magnetic proximity switches.
- » In compliance with ROHS directive
- » PTFE, Silicone and Copper free
- » High reliability
- » High resistance to external loads thanks to the T-guide
- » Variants available for use in ATEX zones and for high temperatures

## GENERAL DATA

|                              |   |
|------------------------------|---|
| <b>Type of construction</b>  | Self-centering parallel gripper with T-guide  |
| <b>Operation</b>             | Single acting (NO, NC), double acting   |
| <b>Bores</b>                 | $\varnothing$ 16, 20, 25, 32, 40 mm   |
| <b>Force transmission</b>    | Lever   |
| <b>Air connections</b>       | M3 ( $\varnothing$ 16), M5 ( $\varnothing$ 20, 25, 32), G1/8 ( $\varnothing$ 40)  |
| <b>Working pressure</b>      | 2 ÷ 8 bar (double acting), 4 ÷ 8 bar (single acting)  |
| <b>Working temperature</b>   | 5°C ÷ 60°C (standard) - 5°C ÷ 150°C (high temperature version)  |
| <b>Store temperature</b>     | -10°C ÷ 80°C  |
| <b>Maximum use frequency</b> | 3 Hz ( $\varnothing$ 16, 20, 25, 32), 2 Hz ( $\varnothing$ 40)  |
| <b>Repeatability</b>         | 0.02 mm   |
| <b>Interchangeability</b>    | 0.1 mm  |
| <b>Medium</b>                | Filtered air in class 7.4.4 according to ISO 8573-1. In case lubricated air is used, we recommend ISOVG32 oil and to never interrupt lubrication. |
| <b>Lubrication</b>           | After 10 million cycles, grease the sliding zones using Molykote DX grease.   |
| <b>Protection class</b>      | IP 40   |
| <b>Compatibility</b>         | ROHS Directive  |
| <b>Certifications</b>        | ATEX (II 2GD c IIC 120°C(T4)-20°C≤T <sub>a</sub> ≤80)   |
| <b>Materials</b>             | PTFE, Silicone and Copper free  |

N.B. Pressurize the pneumatic system gradually in order to avoid uncontrolled movements

**CODING EXAMPLE**

|             |          |           |          |           |          |          |           |
|-------------|----------|-----------|----------|-----------|----------|----------|-----------|
| <b>CGPT</b> | <b>-</b> | <b>16</b> | <b>-</b> | <b>NC</b> | <b>-</b> | <b>W</b> | <b>EX</b> |
|-------------|----------|-----------|----------|-----------|----------|----------|-----------|

|             |   |   |
|-------------|---|---|
| <b>CGPT</b> | SERIES  |   |
| <b>16</b>   | BORES:<br>10 = ø 10 mm<br>16 = ø 16 mm<br>20 = ø 20 mm<br>25 = ø 25 mm<br>32 = ø 32 mm<br>40 = ø 40 mm      |   |
| <b>NC</b>   | FUNCTIONING:<br>= double acting<br>NO = single acting, normally open<br>NC = single acting, normally closed | PNEUMATIC SYMBOLS<br>PNZ1<br>PNZ3<br>PNZ2 |
| <b>W</b>    | VERSION:<br>= standard<br>W = high temperatures (150 °C) - not magnetic                                     |   |
| <b>EX</b>   | Add EX to order the certified ATEX version  |   |

SERIES CGPT SELF-CENTERING PARALLEL GRIPPERS WITH T-GUIDE

**PNEUMATIC SYMBOLS**

The pneumatic symbols which have been indicated in the CODING EXAMPLE are shown below.

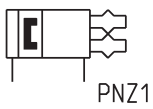

**Maximum admissible loads and torques**

Fz s, Mx s, My s, Mz s =  
maximum admissible loads and  
torques in static conditions  
Fz d, Mx d, My d, Mz d =  
maximum admissible loads and  
torques in dynamic conditions

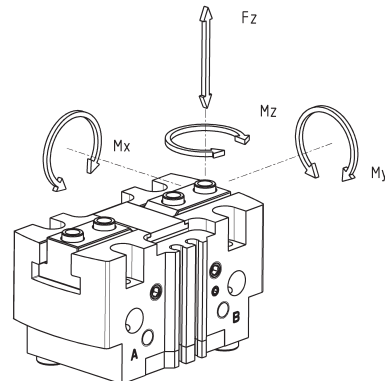

| Mod.           | Fz s (N) | Mx s (Nm) | My s (Nm) | Mz s (Nm) | Fz d (N) | Mx d (Nm) | My d (Nm) | Mz d (Nm) |
|----------------|----------|-----------|-----------|-----------|----------|-----------|-----------|-----------|
| <b>CGPT-16</b> | 200      | 2.5       | 2.5       | 2         | 2        | 0.06      | 0.06      | 0.06      |
| <b>CGPT-20</b> | 350      | 5         | 7.5       | 4         | 4        | 0.12      | 0.12      | 0.12      |
| <b>CGPT-25</b> | 600      | 8         | 13        | 6.5       | 6        | 0.25      | 0.25      | 0.25      |
| <b>CGPT-32</b> | 900      | 18        | 30        | 15        | 9        | 0.5       | 0.5       | 0.5       |
| <b>CGPT-40</b> | 1500     | 40        | 60        | 30        | 15       | 1         | 1         | 1         |

**Series CGPT grippers - construction**

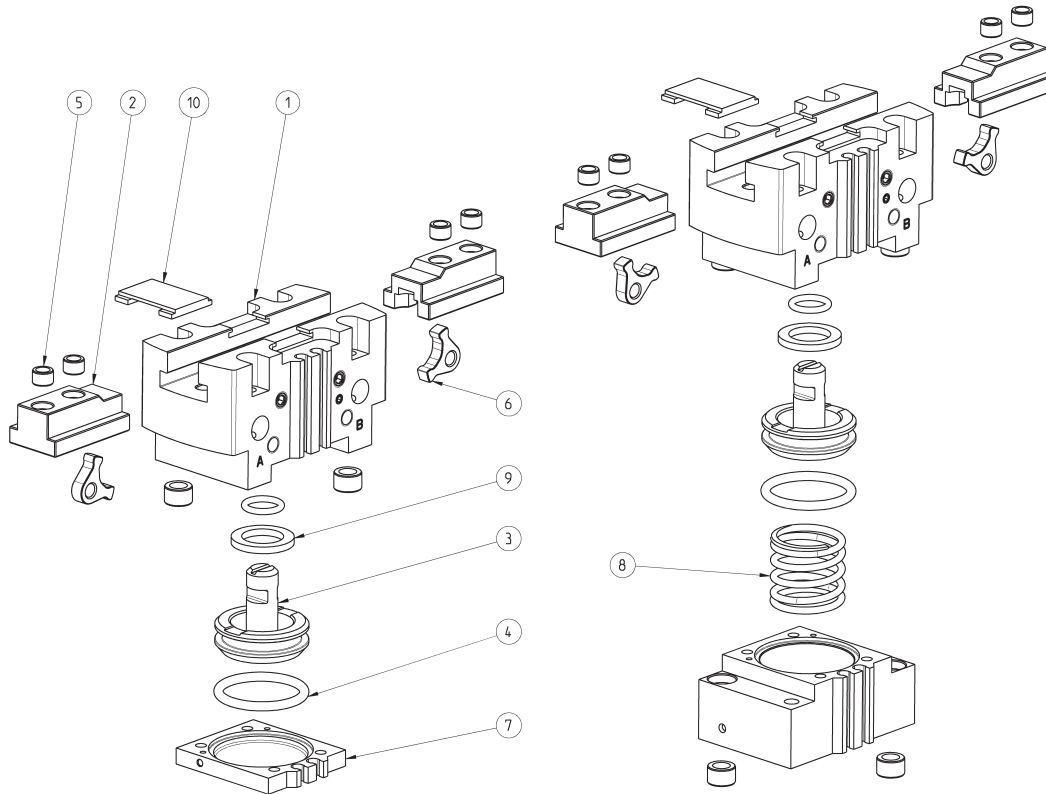

SERIES CGPT SELF-CENTERING PARALLEL GRIPPERS WITH T-GUIDE

| LIST OF COMPONENTS   |                 |
|----------------------|-----------------|
| PARTS                | MATERIALS       |
| 1 - Body             | Aluminium       |
| 2 - Jaw              | Stainless steel |
| 3 - Piston           | Stainless steel |
| 4 - Seals            | HNBR / FKM      |
| 5 - Centering bushes | Stainless steel |
| 6 - Levers           | Steel           |
| 7 - End cover        | Aluminium       |
| 8 - Spring           | Stainless steel |
| 9 - Magnet           | Neodymium       |
| 10 - Cover           | Stainless steel |

**CGPT gripper, size 16 mm - dimensions**



**DRAWING LEGEND:**  
A = Opening of air connection  
B = Closing of air connection  
C = Closed gripper  
D = Open gripper

SERIES CGPT SELF-CENTERING PARALLEL GRIPPERS WITH T-GUIDE

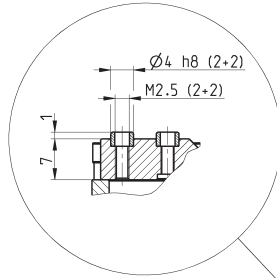
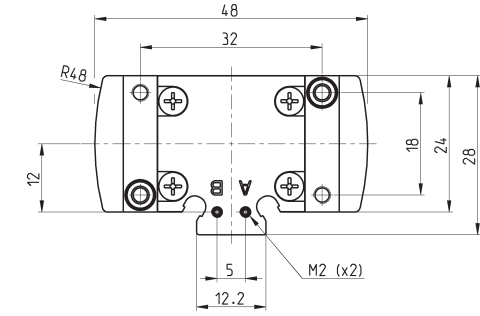

CGPT-16-NO  
CGPT-16-NC

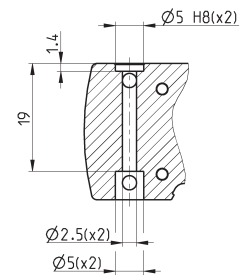
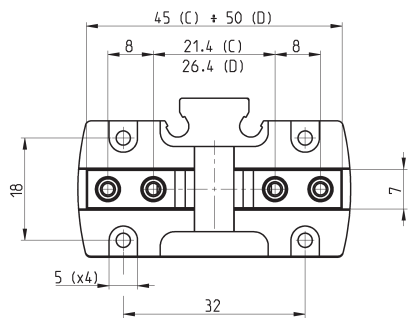
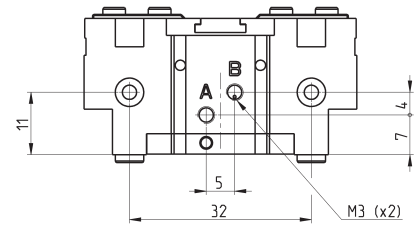
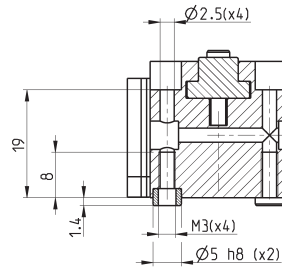
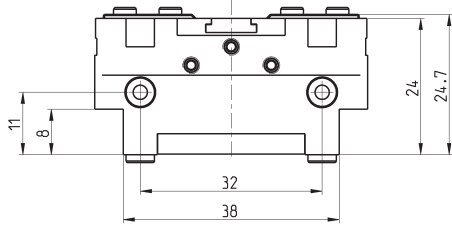
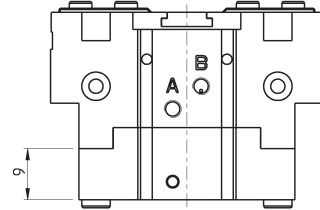

| Mod.       | Total closing gripping force at 6 bar (N) | Closing gripping force each jaw at 6 bar (N) | Total opening gripping force at 6 bar (N) | Opening gripping force each jaw at 6 bar (N) | Stroke per jaw (mm) | Working pressure (bar) | Working temperature (°C) | Repeatability (mm) | Max use frequency (Hz) | Weight (Kg) |
|------------|---|--|---|--|---------------------|------------------------|--------------------------|--------------------|------------------------|-------------|
| CGPT-16    | 114                                       | 57   | 130                                       | 65   | 2.5                 | 2 ÷ 8                  | 5 ÷ 60                   | 0.02               | 3                      | 0.09        |
| CGPT-16-NC | 142                                       | 71   | 90  | 45   | 2.5                 | 4 ÷ 8                  | 5 ÷ 60                   | 0.02               | 3                      | 0.11        |
| CGPT-16-NO | 74  | 37   | 160                                       | 80   | 2.5                 | 4 ÷ 8                  | 5 ÷ 60                   | 0.02               | 3                      | 0.1         |

**CGPT gripper, size 20 mm - dimensions**



**DRAWING LEGEND:**  
 A = Opening of air connection  
 B = Closing of air connection  
 C = Closed gripper  
 D = Open gripper

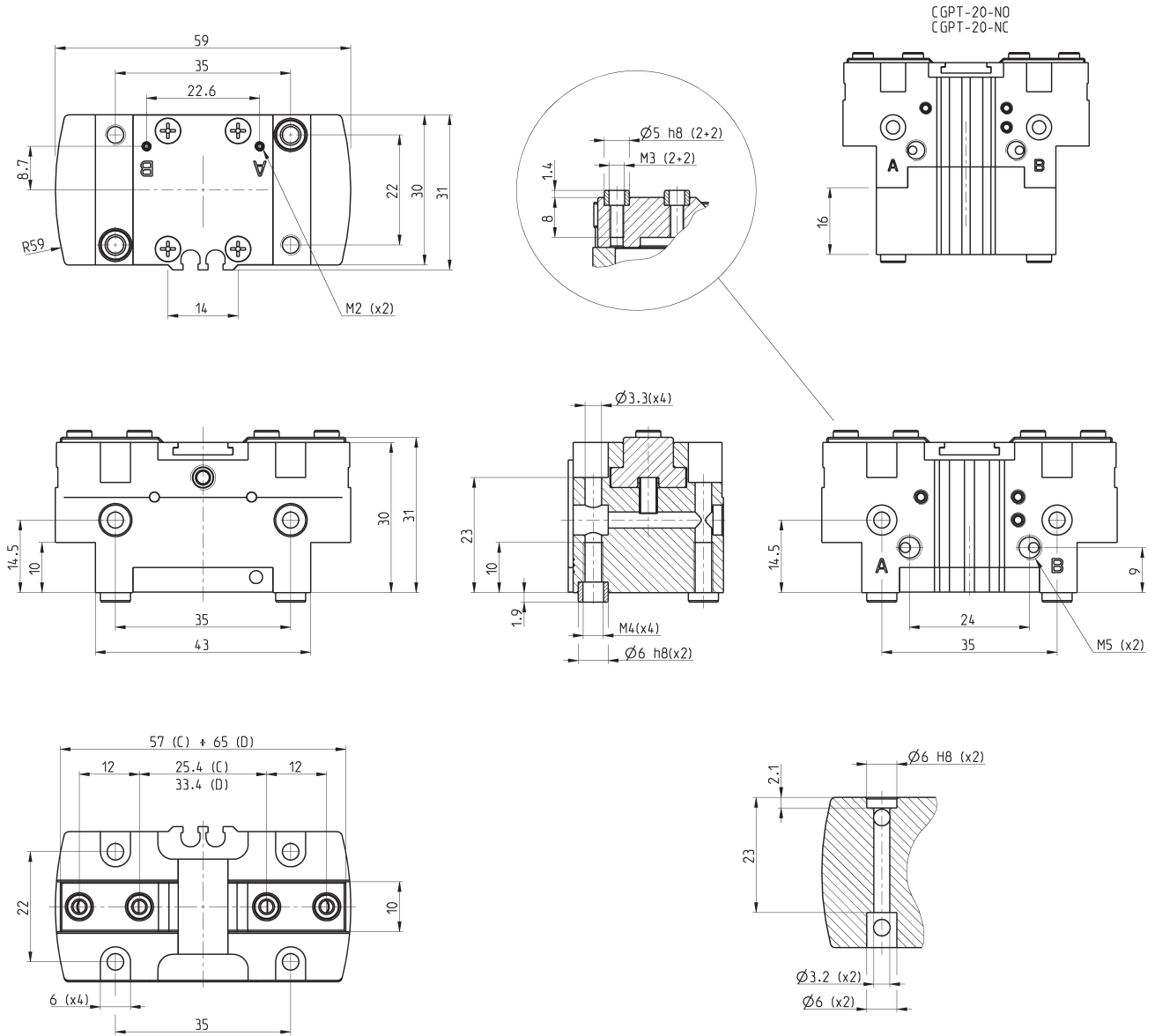

SERIES CGPT SELF-CENTERING PARALLEL GRIPPERS WITH T-GUIDE

| Mod.       | Total closing gripping force at 6 bar (N) | Closing gripping force each jaw at 6 bar (N) | Total opening gripping force at 6 bar (N) | Opening gripping force each jaw at 6 bar (N) | Stroke per jaw (mm) | Working pressure (bar) | Working temperature (°C) | Repeatability (mm) | Max use frequency (Hz) | Weight (Kg) |
|------------|---|--|---|--|---------------------|------------------------|--------------------------|--------------------|------------------------|-------------|
| CGPT-20    | 166                                       | 83   | 188                                       | 94   | 4                   | 2 ÷ 8                  | 5 ÷ 60                   | 0.02               | 3                      | 0.15        |
| CGPT-20-NC | 208                                       | 104  | 102                                       | 51   | 4                   | 4 ÷ 8                  | 5 ÷ 60                   | 0.02               | 3                      | 0.2         |
| CGPT-20-NO | 102                                       | 51   | 246                                       | 123  | 4                   | 4 ÷ 8                  | 5 ÷ 60                   | 0.02               | 3                      | 0.18        |

Products designed for industrial applications.  
 General terms and conditions for sale are available on [www.camozzi.com](http://www.camozzi.com).

1.17.05

**CGPT gripper, size 25 mm - dimensions**



**DRAWING LEGEND:**  
A = Opening of air connection  
B = Closing of air connection  
C = Closed gripper  
D = Open gripper

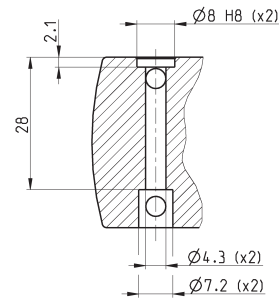
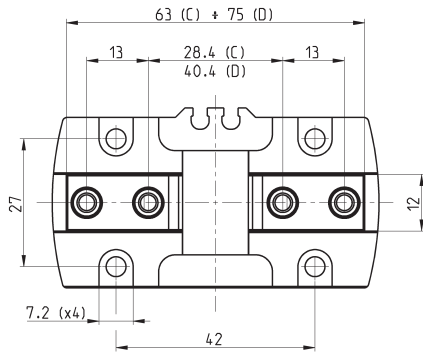
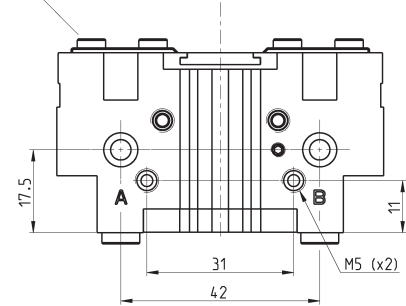
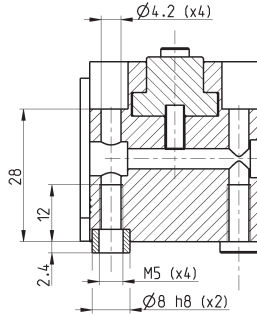
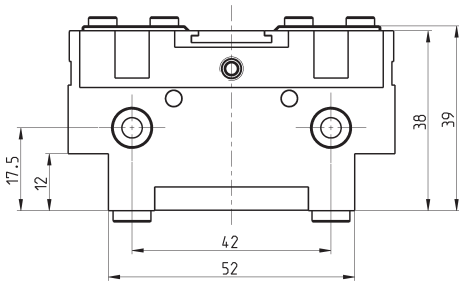
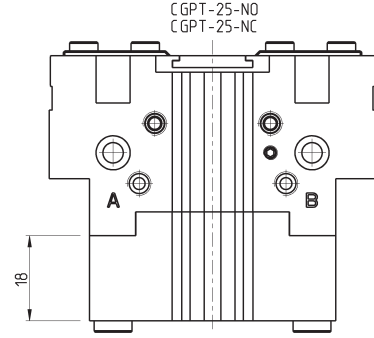
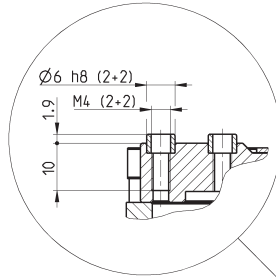
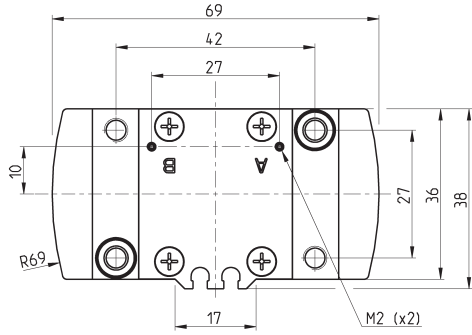

| Mod.       | Total closing gripping force at 6 bar (N) | Closing gripping force each jaw at 6 bar (N) | Total opening gripping force at 6 bar (N) | Opening gripping force each jaw at 6 bar (N) | Stroke per jaw (mm) | Working pressure (bar) | Working temperature (°C) | Repeatability (mm) | Max use frequency (Hz) | Weight (Kg) |
|------------|---|--|---|--|---------------------|------------------------|--------------------------|--------------------|------------------------|-------------|
| CGPT-25    | 236                                       | 118  | 280                                       | 140  | 6                   | 2 ÷ 8                  | 5 ÷ 60                   | 0.02               | 3                      | 0.27        |
| CGPT-25-NC | 286                                       | 143  | 206                                       | 103  | 6                   | 4 ÷ 8                  | 5 ÷ 60                   | 0.02               | 3                      | 0.35        |
| CGPT-25-NO | 166                                       | 83   | 330                                       | 165  | 6                   | 4 ÷ 8                  | 5 ÷ 60                   | 0.02               | 3                      | 0.33        |

**CGPT gripper, size 32 mm - dimensions**



**DRAWING LEGEND:**  
 A = Opening of air connection  
 B = Closing of air connection  
 C = Closed gripper  
 D = Open gripper

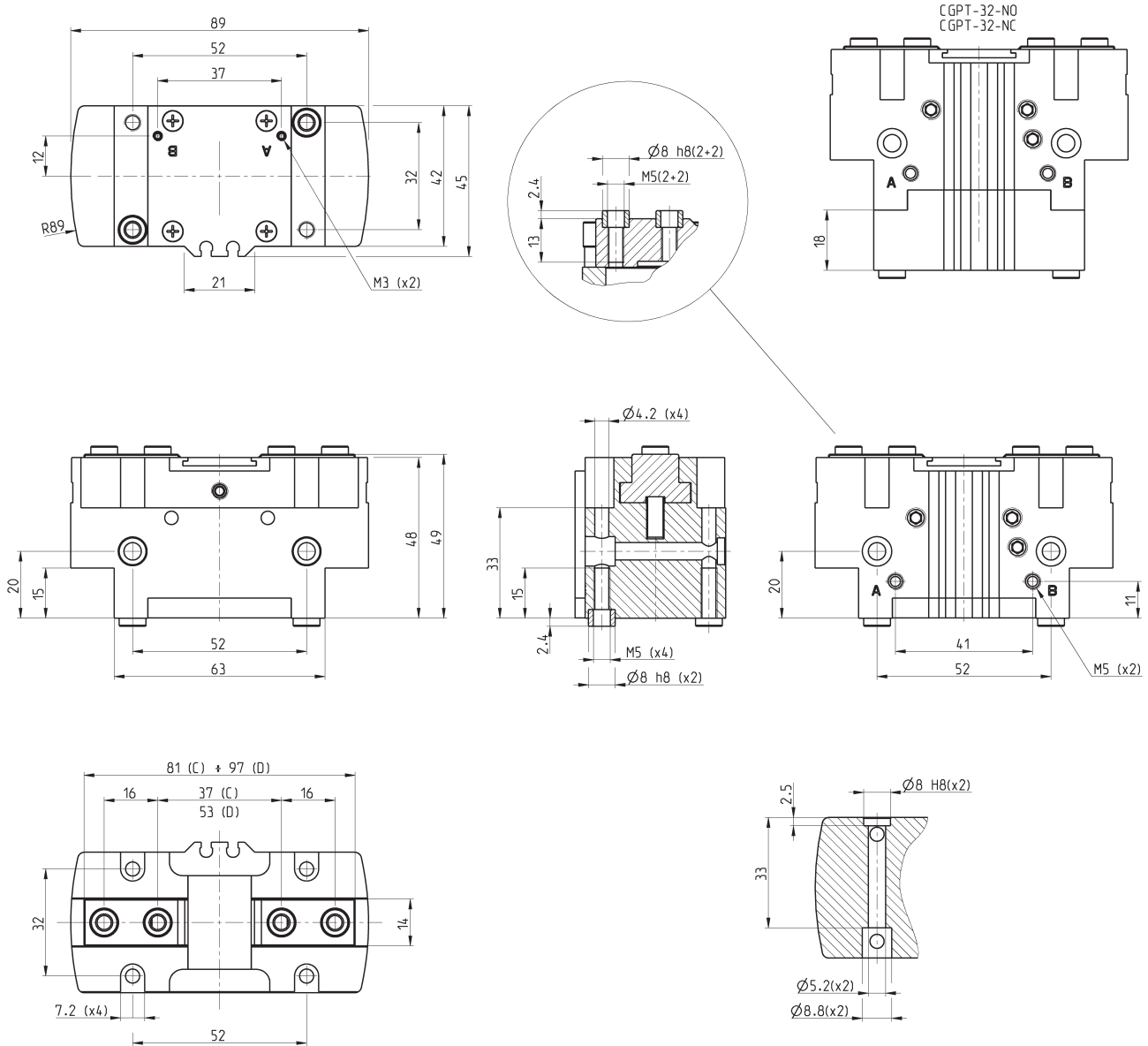

SERIES CGPT SELF-CENTERING PARALLEL GRIPPERS WITH T-GUIDE

| Mod.       | Total closing gripping force at 6 bar (N) | Closing gripping force each jaw at 6 bar (N) | Total opening gripping force at 6 bar (N) | Opening gripping force each jaw at 6 bar (N) | Stroke per jaw (mm) | Working pressure (bar) | Working temperature (°C) | Repeatability (mm) | Max use frequency (Hz) | Weight (Kg) |
|------------|---|--|---|--|---------------------|------------------------|--------------------------|--------------------|------------------------|-------------|
| CGPT-32    | 386                                       | 193  | 450                                       | 225  | 8                   | 2 ÷ 8                  | 5 ÷ 60                   | 0.02               | 3                      | 0.5         |
| CGPT-32-NC | 454                                       | 227  | 354                                       | 177  | 8                   | 4 ÷ 8                  | 5 ÷ 60                   | 0.02               | 3                      | 0.61        |
| CGPT-32-NO | 294                                       | 147  | 520                                       | 260  | 8                   | 4 ÷ 8                  | 5 ÷ 60                   | 0.02               | 3                      | 0.59        |

Products designed for industrial applications.  
 General terms and conditions for sale are available on [www.camozzi.com](http://www.camozzi.com).

1.17.07

**CGPT gripper, size 40 mm - dimensions**



**DRAWING LEGEND:**  
A = Opening of air connection  
B = Closing of air connection  
C = Closed gripper  
D = Open gripper

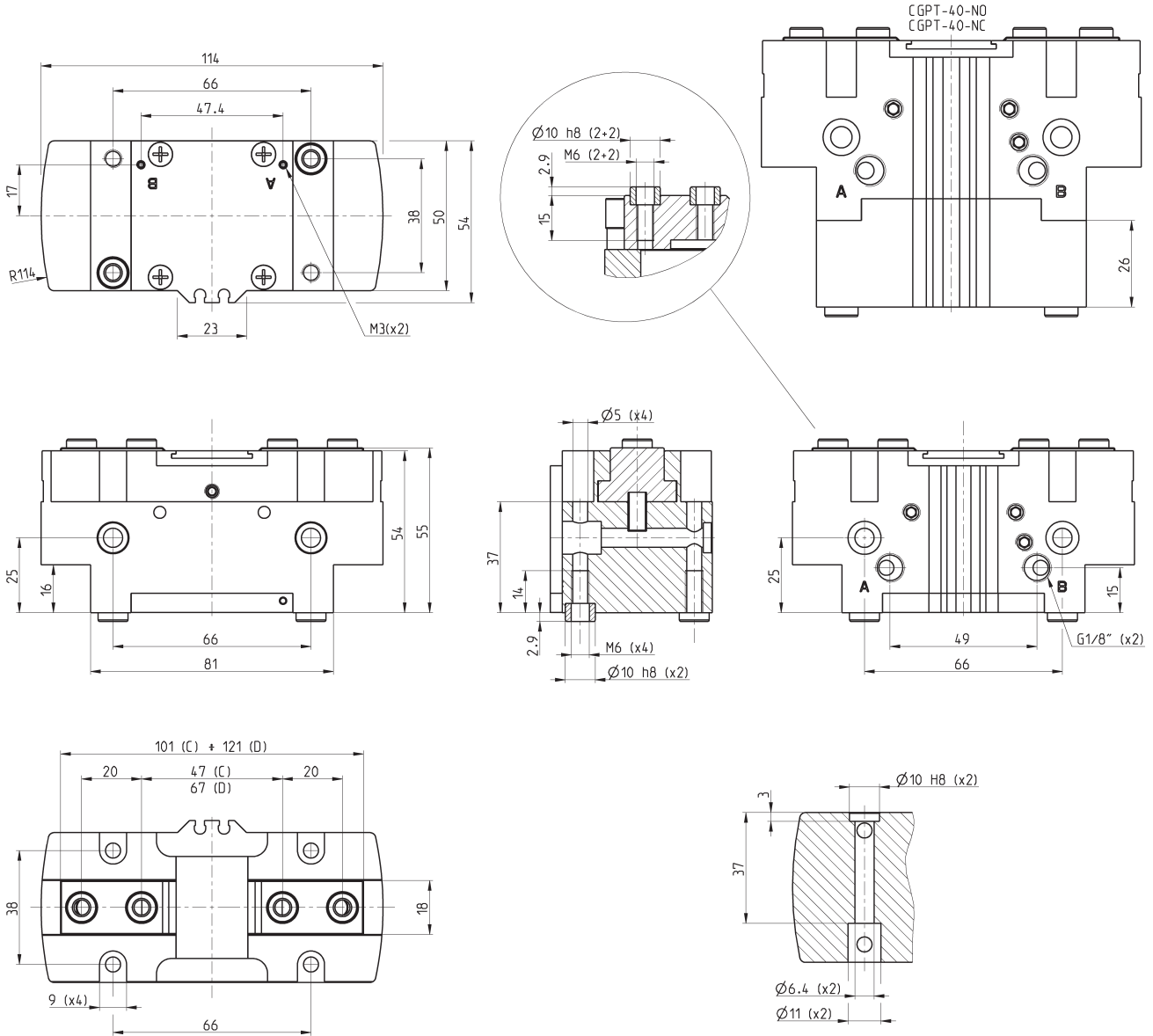

SERIES CGPT SELF-CENTERING PARALLEL GRIPPERS WITH T-GUIDE

| Mod.       | Total closing gripping force at 6 bar (N) | Closing gripping force each jaw at 6 bar (N) | Total opening gripping force at 6 bar (N) | Opening gripping force each jaw at 6 bar (N) | Stroke per jaw (mm) | Working pressure (bar) | Working temperature (°C) | Repeatability (mm) | Max use frequency (Hz) | Weight (Kg) |
|------------|---|--|---|--|---------------------|------------------------|--------------------------|--------------------|------------------------|-------------|
| CGPT-40    | 670                                       | 335  | 720                                       | 360  | 10                  | 2 ÷ 8                  | 5 ÷ 60                   | 0.02               | 2                      | 0.83        |
| CGPT-40-NC | 780                                       | 390  | 504                                       | 252  | 10                  | 4 ÷ 8                  | 5 ÷ 60                   | 0.02               | 2                      | 1.2         |
| CGPT-40-NO | 446                                       | 223  | 826                                       | 413  | 10                  | 4 ÷ 8                  | 5 ÷ 60                   | 0.02               | 2                      | 1.1         |



**GRIPPING FORCE (Fc) PER SINGLE JAW**

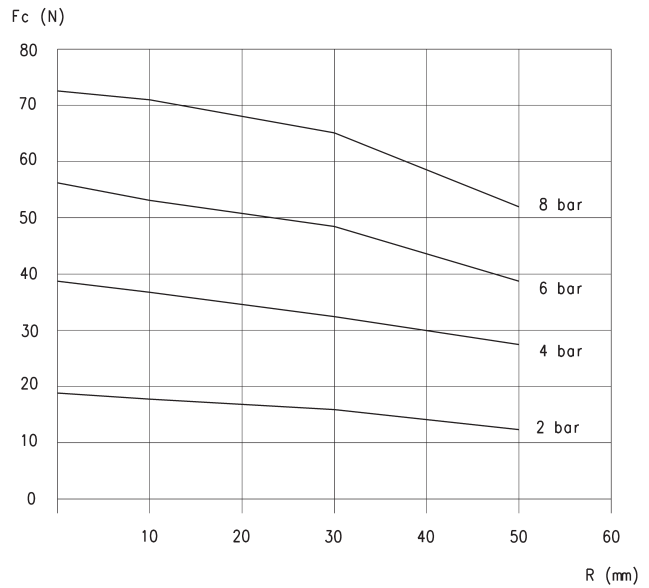
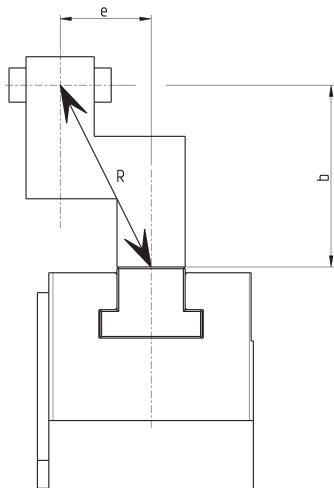

The total gripping force has to be calculated as follows:  
Total Fc = Fc x 2

Gripping force in relation to the lever arm (R)  
and the eccentricity (b, e)

$$R = \sqrt{b^2 + e^2}$$

CGPT-16

R = lever arm  
Fc = closing gripping force

$$Fa \text{ (opening gripping force)} = Fc + 10\%$$

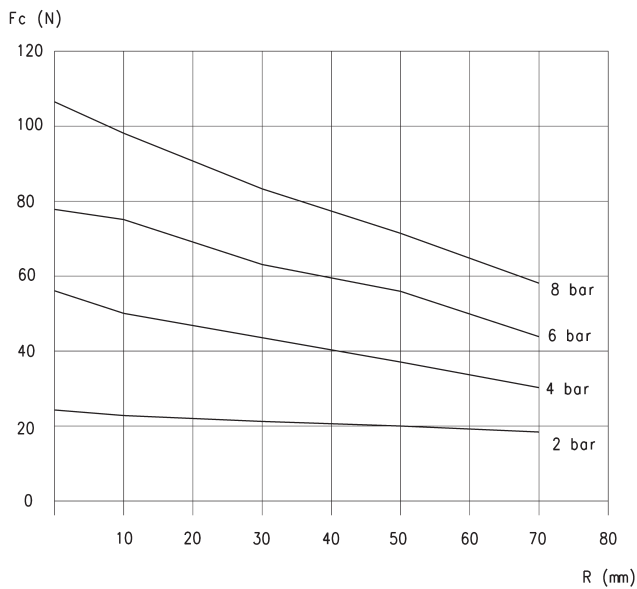

CGPT-20

R = lever arm  
Fc = closing gripping force

$$Fa \text{ (opening gripping force)} = Fc + 10\%$$

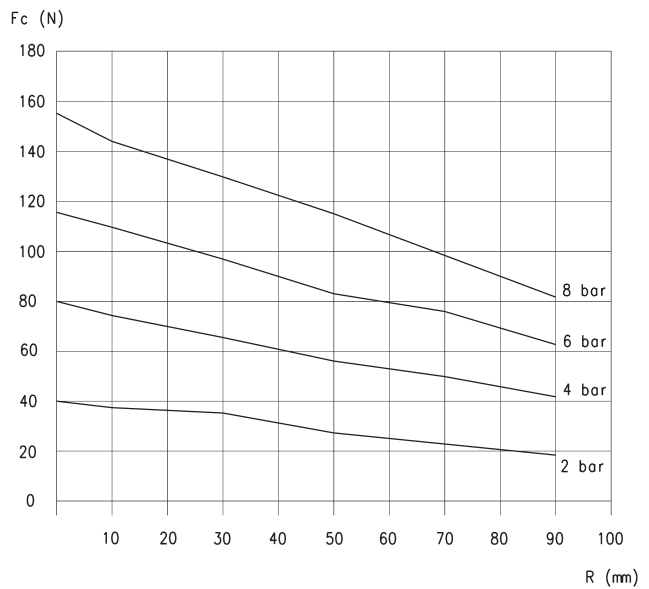

CGPT-25

R = lever arm  
Fc = closing gripping force

$$Fa \text{ (opening gripping force)} = Fc + 10\%$$

SERIES CGPT SELF-CENTERING PARALLEL GRIPPERS WITH T-GUIDE

**GRIPPING FORCE (Fc) PER SINGLE JAW**

SERIES CGPT SELF-CENTERING PARALLEL GRIPPERS WITH T-GUIDE

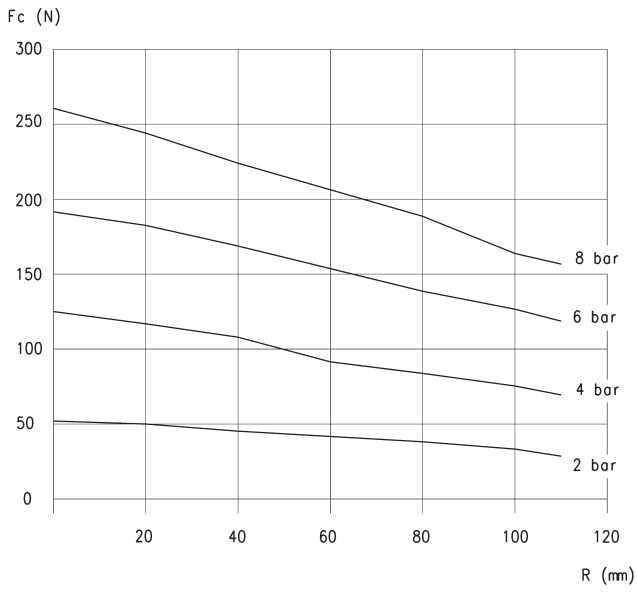

**CGPT-32**

R = lever arm

Fc = closing gripping force

Fa (opening gripping force) = Fc + 10%

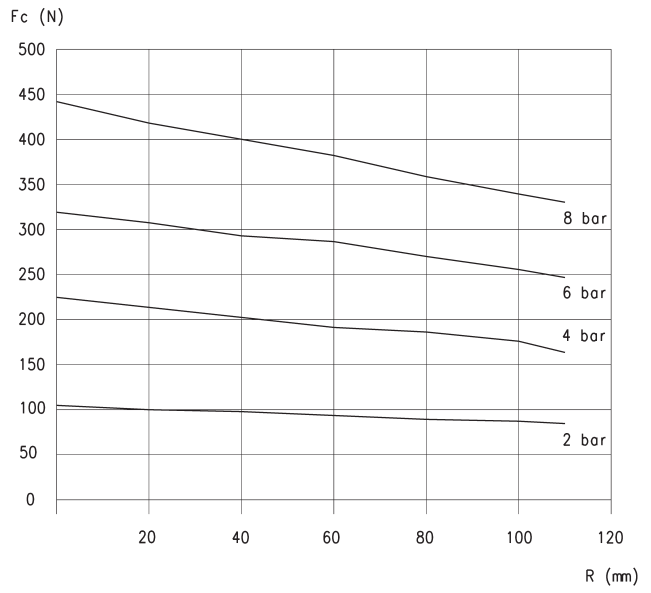

**CGPT-40**

R = lever arm

Fc = closing gripping force

Fa (opening gripping force) = Fc + 10%

## Examples of mounting

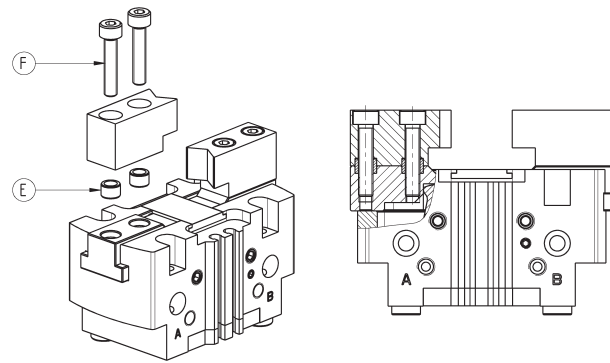
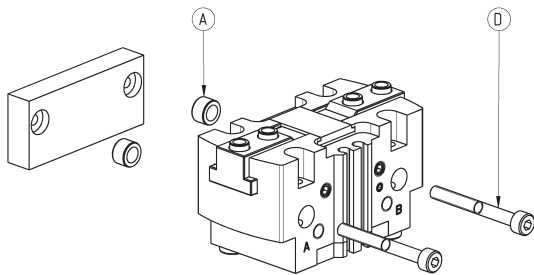
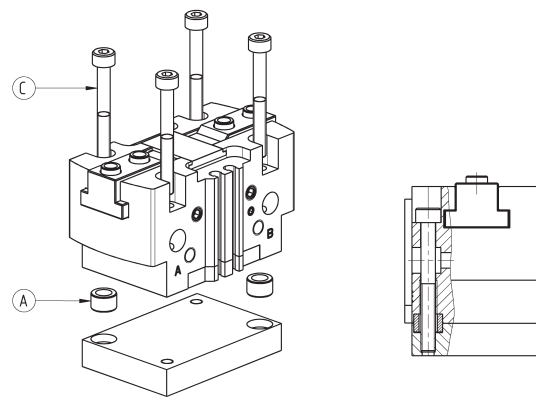
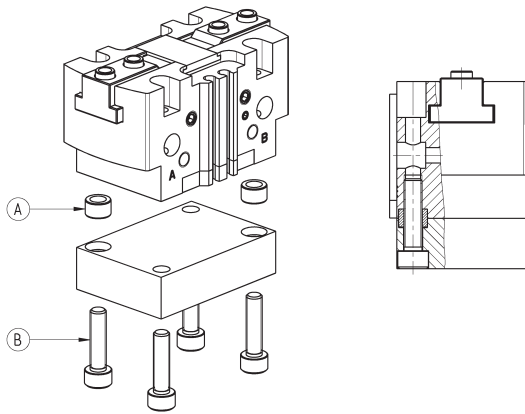

SERIES CGPT SELF-CENTERING PARALLEL GRIPPERS WITH T-GUIDE

| Mod.    | A   | B  | C    | D    | E   | F    |
|---------|-----|----|------|------|-----|------|
| CGPT-16 | Ø5  | M3 | M2.5 | M2.5 | Ø4  | M2.5 |
| CGPT-20 | Ø6  | M4 | M3   | M3   | Ø5  | M3   |
| CGPT-25 | Ø8  | M5 | M4   | M4   | Ø6  | M4   |
| CGPT-32 | Ø8  | M5 | M4   | M5   | Ø8  | M5   |
| CGPT-40 | Ø10 | M6 | M5   | M6   | Ø10 | M6   |

## Air supply ports

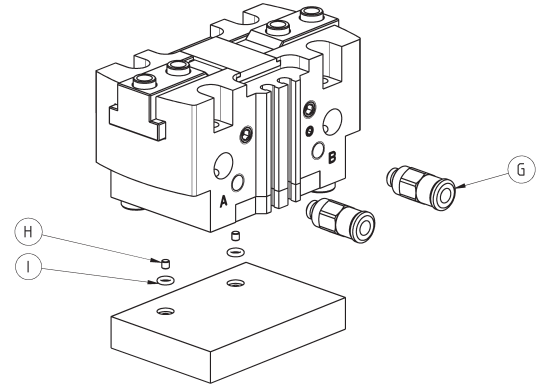

| Mod.    | G    | H  | I        |
|---------|------|----|----------|
| CGPT-16 | M3   | M2 | OR 1x2.5 |
| CGPT-20 | M5   | M2 | OR 1x2.5 |
| CGPT-25 | M5   | M2 | OR 1x2.5 |
| CGPT-32 | M5   | M3 | OR 1x3.5 |
| CGPT-40 | G1/8 | M3 | OR 1x3.5 |

## Example of use of the pressurization/lubrication hole

Example of use of the lubrication (greasing) or pressurization hole of the zone with moving items

NOTE 1: grease the sliding zones using Molykote DX grease.

NOTE 2: supply a pressure of max. 3 bar in order to avoid the sudden ejection of grease.

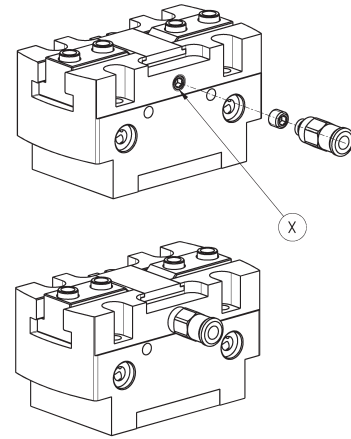

| Mod.    | X  |
|---------|----|
| CGPT-16 | M3 |
| CGPT-20 | M5 |
| CGPT-25 | M5 |
| CGPT-32 | M5 |
| CGPT-40 | M5 |

## Example of mounting: sensors

L = sensor mod. CSD-332 or mod. CSD-362

In order to position the sensor correctly, a channel must be created in the base.

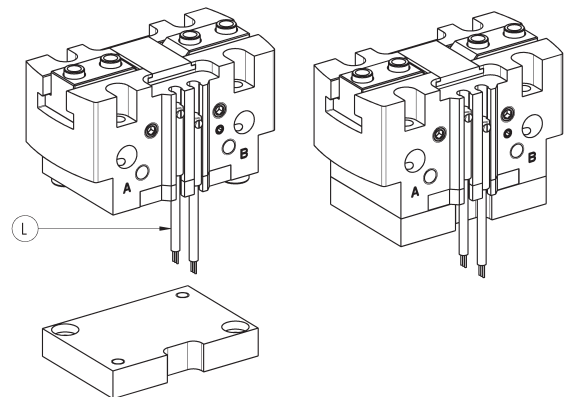

|         |
|---------|
| Mod.    |
| CGPT-16 |
| CGPT-20 |
| CGPT-25 |
| CGPT-32 |
| CGPT-40 |

### Series CSD magnetic proximity switches with 3-wire cable

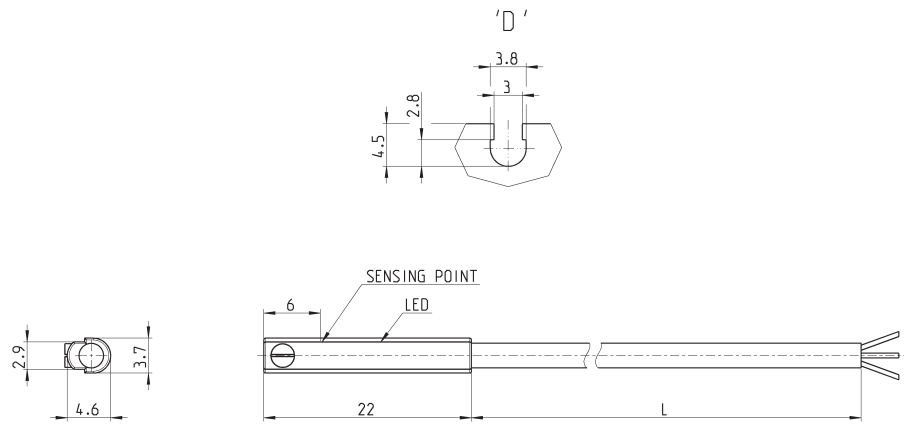

| Mod.    | Operation  | Connections | Voltage      | Output | Max. current | Max Load | Protection                                 | L = length cable |
|---------|------------|-------------|--------------|--------|--------------|----------|--|------------------|
| CSD-332 | Electronic | 3 wires     | 10 ÷ 27 V DC | PNP    | 200 mA       | 6W       | Against polarity reversing and overvoltage | 2 m              |

### Series CSD magnetic proximity switches with male connector M8

Length of cable 0.3 metres

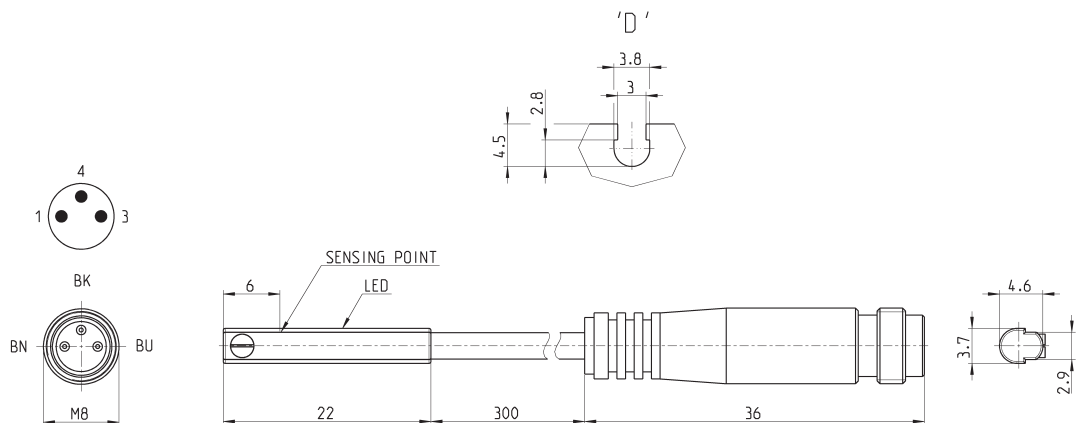

| Mod.    | Operation  | Connection                | Voltage      | Output | Max. current | Max load | Protection                                 |
|---------|------------|---------------------------|--------------|--------|--------------|----------|--|
| CSD-362 | Electronic | 3 wires with M8 connector | 10 ÷ 27 V DC | PNP    | 200 mA       | 6W       | Against polarity reversing and overvoltage |