

Series QR

Rotary actuators with rack and pinion system

Magnetic, cushioned

7, 10, 20, 30, 50 mm

Rotation angles: 0 - 190°



- » Compact design
- » High rotation stability
- » Adjustable rotation angle
- » Easy to install
- » Mechanical or hydraulic shock absorbers
- » Can be integrated into manipulation systems

The Series QR rotary actuators are cylinders with a double piston, able to provide high torques while ensuring high stability and a precise rotary movement. The rotation angle can be easily set as desired between 0° and 190° by means of adjustment bolts or hydraulic absorbers positioned on one side of the rotary table. The use of shock absorbers allows the dampening of two to five times more kinetic energy than with regulation bolts. The rotary table is compact and allows direct mounting of the load. Their compact design, lightness and ease to combine with EOAT make these actuators particularly suitable for use in the assembly and packaging sectors and any application that requires transfer, tilting or rotation of objects.

GENERAL DATA

Type of construction	"Rack & Pinion" system
Operation	double-acting
Materials	profile, end blocks and rotor = aluminium - rack = steel - pinion = steel - rack's guide ring = PTFE - seals = NBR
Type of mounting	by means of screws in the central body
Sizes	07, 10, 20, 30, 50
Operating temperature	0°C ÷ 70°C
Standard rotation angles	0 - 190°
Minimum rotation angle (with shock absorber)	10 = 66°, 20 = 52°, 30 = 46°, 50 = 70°
Repeatability	<0.2°
Bearings	ball bearings
Operating pressure	1 - 10bar, 1 - 7bar (for 7mm), 1-6bar (for versions with shock absorber)
Medium	filtered air in class 7.8.4 according to ISO 8573-1 standard. If lubricated air is used, it is recommended to use oil ISOVG32. Once applied the lubrication should never be interrupted.

CODING EXAMPLE

QR	20	A
-----------	-----------	----------

QR	SERIES	PNEUMATIC SYMBOL CD18
20	SIZE: 07 10 20 30 50	
A	TYPE OF CUSHIONING: A = MECHANICAL STOP S = SHOCK ABSORBER	

SERIE QR ROTARY ACTUATOR

PNEUMATIC SYMBOL

The pneumatic symbol indicated in the CODING EXAMPLE is reported below.



MAXIMUM PERMISSIBLE KINETIC ENERGY AND ROTATION TIMES

Size	Maximum permissible kinetic energy (J)		Setting range of rotation time for stable use (s/90°)	
	With adjustment bolt	With shock absorber	With adjustment bolt	With shock absorber
07	0.006	-	0.2 - 1.0	-
10	0.01	0.04	0.2 - 1.0	0.2 - 1.0
20	0.025	0.12	0.2 - 1.0	0.2 - 1.0
30	0.05	0.12	0.2 - 1.0	0.2 - 1.0
50	0.08	0.30	0.2 - 1.0	0.2 - 1.0

GEOMETRIC TOLERANCES OF THE ROTARY TABLE

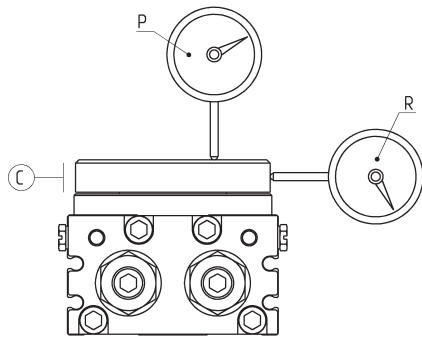

- P = Parallelism of the rotary table 0,1mm
- R = Roundness of the rotary table 0,1mm
- C = Cylindricity of the rotary table 0,1mm

MISALIGNMENT OF THE ROTARY TABLE

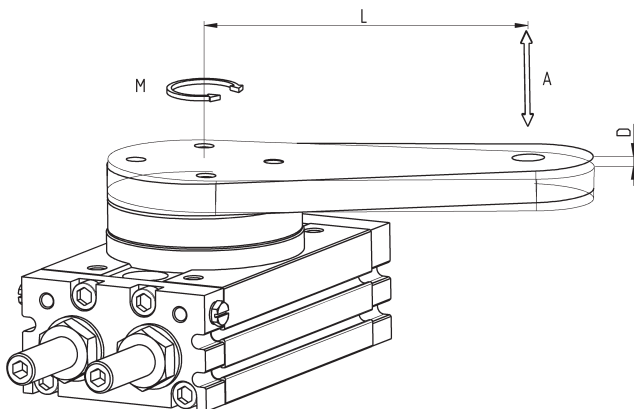

- M = Moment/torque
- L = Arm
- D = Misalignment table

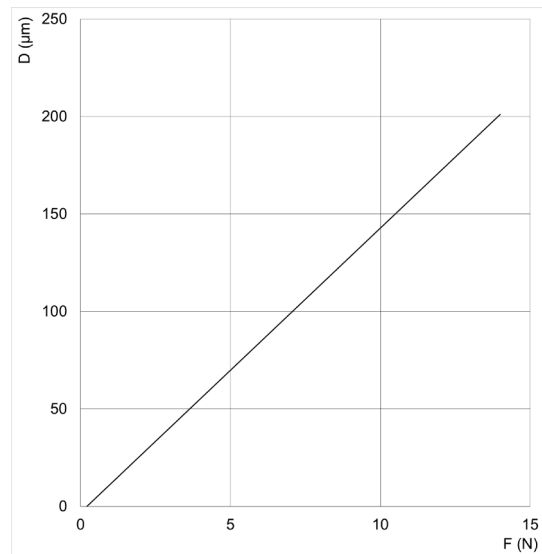

- QR07
- D = Misalignment
- F = Force

MISALIGNMENT OF THE ROTARY TABLE

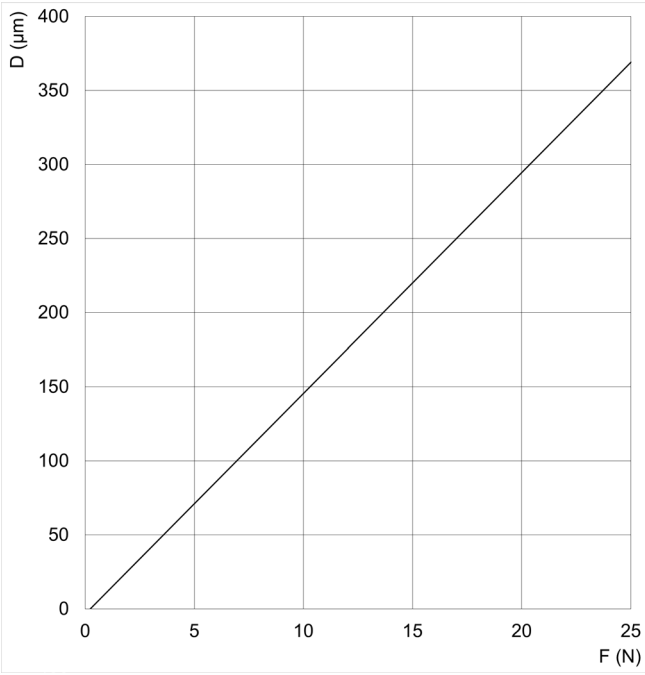

QR10

D = Misalignment
F = Force

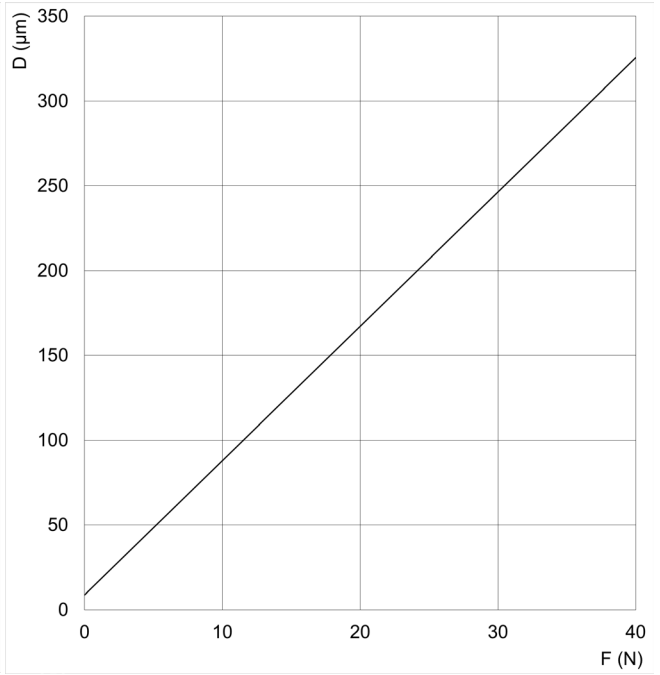

QR20

D = Misalignment
F = Force

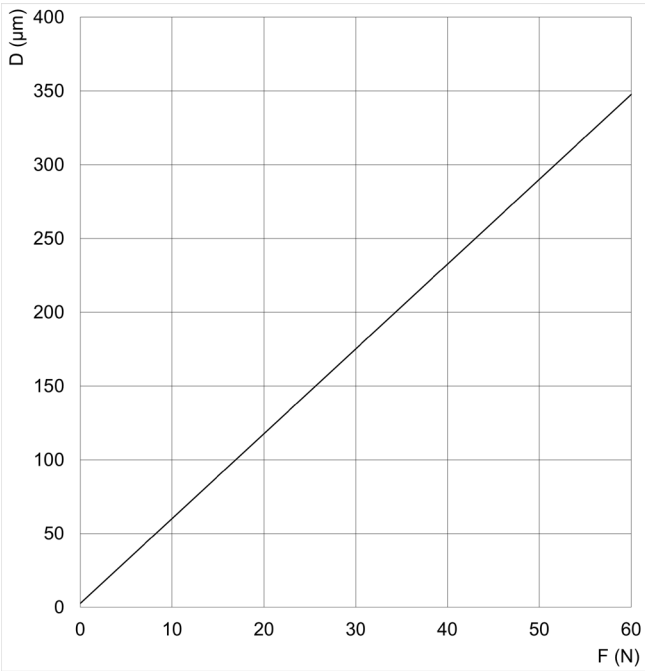

QR30

D = Misalignment
F = Force

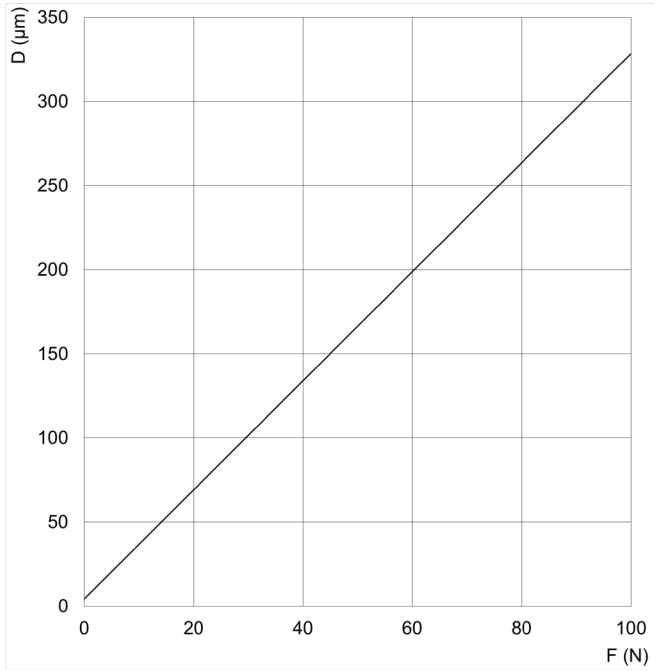

QR50

D = Misalignment
F = Force

OUTPUT TORQUE AND PERMISSIBLE LOADS

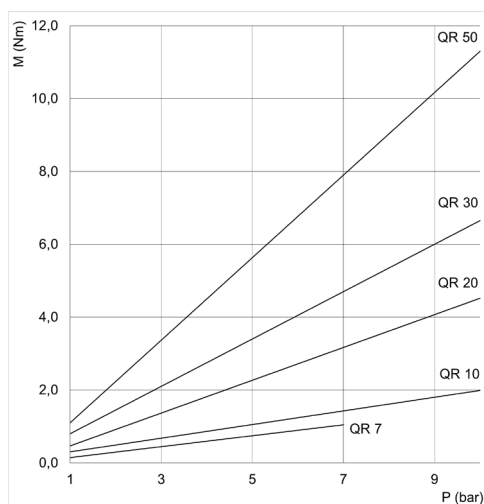

M = Output torque
P = Pressure

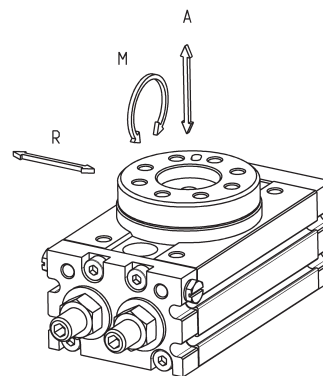

Maximum permissible load

Size	R radial (N)	A axial (N)	M moment (Nm)
07	47	65	1.3
10	75	73	2.3
20	142	132	3.9
30	192	189	5.1
50	309	291	9.5

SIZING / CHOICE OF THE CYLINDER

To choose the correct cylinder, follow the procedure below:

- 1) Calculate the moment of inertia of the load (multiple loads generate different moments that must be added together)
- 2) Calculate the necessary output torque (M) considering the following type of application:

- Static Torque (Cs): $M = Cs = Fs \cdot d$ [Nm]
Fs = Static force [N]
d = distance between the force and the center of rotation [m]
- Resistant Torque (Cr): $M = (3 \div 5) \cdot Cr = (3 \div 5) \cdot Fd \cdot d$ [Nm]
Fd = Dynamic force [N]
d = distance between the force and the center of rotation [m]
- Inertial Torque (Ci): $M = 10 \cdot Ci = 10 \cdot Mi \cdot \dot{\omega}$ [Nm]
Mi = Moment of inertia [kg/m²]
 $\dot{\omega}$ = angular acceleration [rad/s²]

Note: When the resistant torque is put into rotation, the necessary torque calculated on the inertial torque must be added

$$M = Cr \cdot (3 \div 5) + Ci \cdot 10$$

- 3) Make sure that the rotation time meets the requirements (please, see the appropriate table at the beginning of the section)
- 4) Check if the kinetic energy of the load is lower than the maximum permissible kinetic energy (please, see the table at the beginning of the section)

If the kinetic energy of the load exceeds the allowable limit, consider installing an adequate external cushioning

- 5) Make sure that the load applied to the product is less than the maximum permissible load (please, see the appropriate table at the top of the page)

If the load exceeds the maximum allowable value, consider installing external supports, bearings, slides or similar. If needed, check the air consumption required by the cylinder based on the flow rate of the circuit.

SERIES QR ROTARY ACTUATORS



* increase in "A" and "Z" for each 90° of rotation

SERIE QR ROTARY ACTUATOR

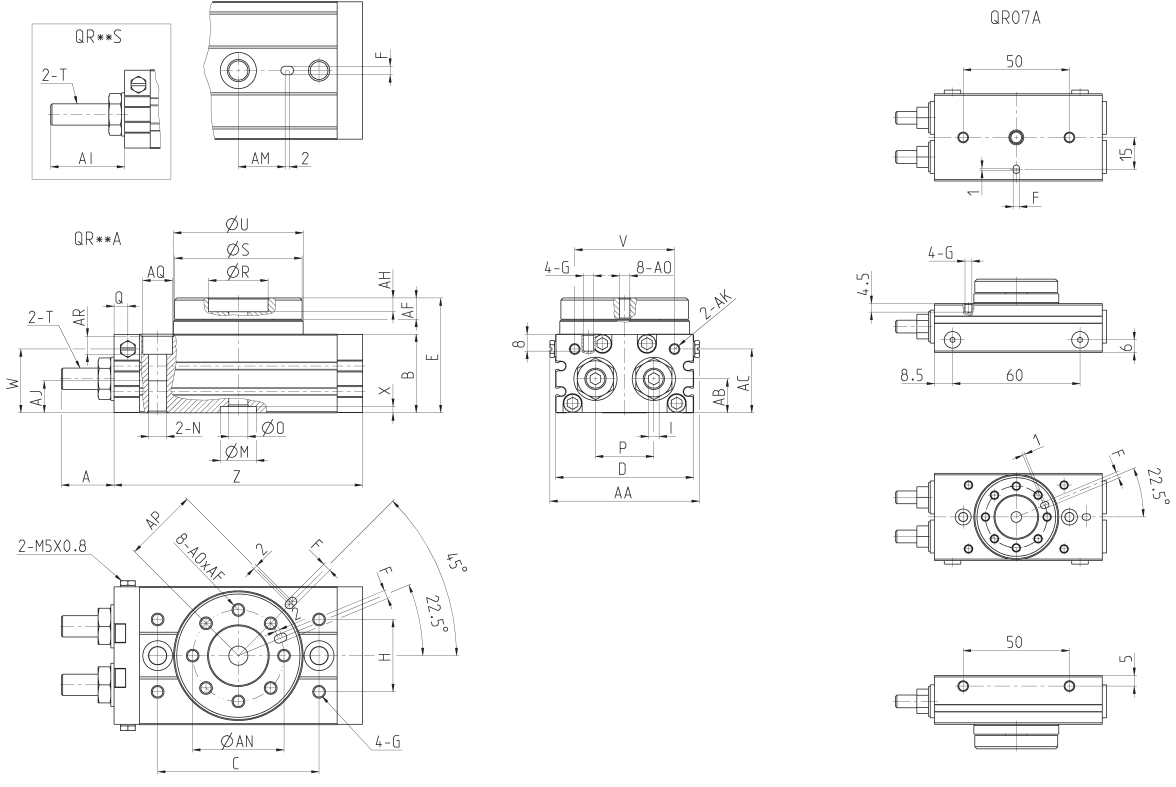

Mod.	A	B	C	D	E	F	G	H	I	L	M	N	O	P	Q	R	S	T	U	V	W	X	Y	Z
07	18.3	23	45	41	34.5	3	M4X0.7	30	3	-	7	M5x0,8	6	18.4	-	20	39	M4X0.7	40	-	-	-	M5X0.8	79
10	17.3	34	60	55.4	47	3	M5X0.8	27	4	9.5	15	M8x1,25	5	20	5	20	45	M8X1	46	34.5	28	3.5	M8X1.25	92
20	24.8	37	76	70.4	54	4	M6X1	34	5	12	17	M10x1,5	9	27.5	6.5	28	60	M10X1	61	47	30	3	M10X1.5	117
30	24.8	40	84	75	57	4	M6X1	37	5	12	22	M10x1,5	10	29	7	32	65	M10X1	67	50	33.5	3.5	M10X1.5	127
50	31.3	46	100	85	66	5	M8X1.25	50	6	15.5	26	M12x1,75	11	38	10	35	75	M104X1.5	77	63	37.5	3.5	M12X1.75	152

Mod.	AA	AB	AC	AF	AH	AI	AJ	AK	AM	AN	AO	AP	AQ	AR
07	42.7	12.2	-	6.3	3	-	-	-	-	29	M4X0.7	32.5	7.5	4.5
10	55.4	15.5	28	8	4.5	30.9	12	M5X0.8	19	32	M5X0.8	27	11	6.5
20	70.4	16	30	10	6.5	34.8	15	M5x0.8	24	43	M6x1	36	14	8.5
30	75	18.5	32	10	5	34.8	15	1/8"	28	48	M6x1	39	14	8.5
50	85	22	37.5	12	5.5	51.3	18	1/8"	33	55	M8x1.25	45	18	10.5